

ESD VALVES

PNEUMATIC VALVES - 2-WAY NORMALLY CLOSED

1/4" FEMALE NPT, 150 PSI MAX, PANEL MOUNT, RED KNOB, H2S SVC

Model 16RS36

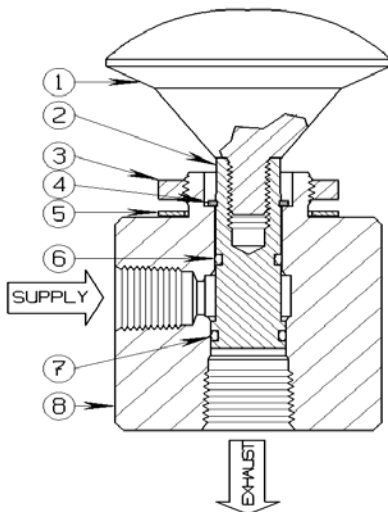

The **16RS36** is a two position, two-way normally closed, high flow capacity manually operated ESD control valve. In the shelf or normal placement, the valve has the Supply port blocked or isolated from the Exhaust port. Pulling outward on the ESD Valve's knob will establish a Supply-to-Exhaust flow path, rapidly depressurizing the ESD control circuit.

Two-way normally closed, ESD Valves of this type are used in Emergency Shutdown (ESD) control circuits to immediately close SSV or SDV Actuators and Surface Controlled Sub-Surface Safety Valves. These controls are most commonly found in parallel ESD control circuits on many offshore platforms. They are normally installed or mounted on platform handrail ESD Stations near boat ramps and heliports.

Stainless steel construction virtually eliminates corrosion freeze-up, and Sigma valves are rugged enough to help prevent accidental activation of your safety system.

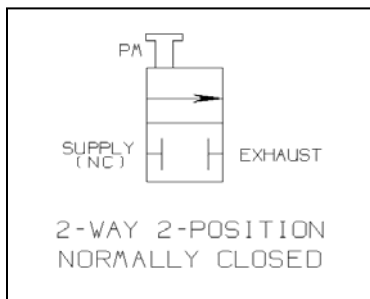

PARTS LIST:

- | | |
|------------------------|----------------|
| 1. Red Phenolic Handle | 5. Seal Ring * |
| 2. Plunger | 6. O Ring * |
| 3. Panel Nut | 7. O Ring * |
| 4. Snap Ring * | 8. Valve Body |

Black phenolic handles and custom engraved signs available upon request.

* Indicates parts included in a Repair Kit

Sigma Model Number 16RS36
1/4" FEMALE NPT, 150 PSI MAX, PANEL MOUNT, RED KNOB, H2S SVC
(Panel Mount)

Product Specifications

Flow Control Application: Normally Closed – Pull to Actuate

Control Function: Two-Way

Pressure Rating Body (Control Ports): 150 PSI maximum (10.34 bar)

Media Service: Pneumatic, Hydraulic

Connection Size (Body): 1/4-18 Female N.P.T. Supply, 3/8-18 Female N.P.T. Exhaust

Orifice: 1/4 Diameter **Cv Factor:** 1.13

Component Material (Metal): 316 Stainless Steel

Seal Material: Viton

Panel Mount: Yes

Panel Hole Cutout Size Required: 1 Diameter

Weight: 1.5 Lbs.

Operating Temperature: -20° F to +250° F (-29° C to +121° C)

Overall Dimensions: 3-1/2 Height x 2 Diameter (8.89 cm Height x 5.08 cm Diameter)

Installation and Maintenance Instructions:

Remove the Handle (#1) and Panel Nut (#3). Insert in pre-drilled 1" diameter hole. Replace the Panel Nut and Handle. Connect the control line to the Supply side and connect the Exhaust to the appropriate connection. Sigma recommends the use of appropriate thread sealant for each port connection.

Shelf Position Port Status

Inlet	Instrument supply pressure normally closed
Exhaust	Depressurizes instrument supply upon actuation

Note:

The 16RS36 ESD Valve can be ordered with a Pipe Mountable ESD Sign which includes a 6 x 12 Red Background/Large Letter, Stainless Steel Sign with U-Bolts, ready for Handrail installation.

Repair Kit Information

Repair Kits contain all of the Seals and other components typically replaced when repairing the assembly. In order to maintain optimum operating control function.