

Manual Reset Relay

3-Way Normally Closed

1/4" FEMALE NPT, PULL TO OPEN, H2S SVC

Model 11LV36



Conforms to the SEP category of the European Pressure Equipment Directive
Issue No. 97/23/EC

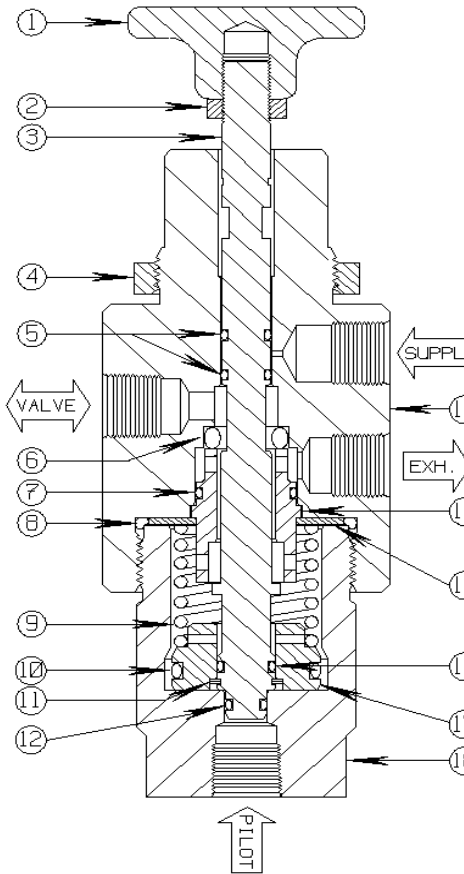

The 11LV36 is a two position, three-way normally closed block and bleed Manual Reset Relay valve. It is designed to establish Supply-to-Valve output pressure with manual **Pull** positioning of the Knob.

Once the Black Knob is pulled outward and Pilot Supply pressure is applied, the Relay's normal in-service placement will be maintained. A loss of Pilot Supply pressure will block the Supply (inlet) port and exhaust the accumulated pressure within the receiving control circuit. This type of relay valve is most frequently used to control the open/close operating sequence of a Surface Safety Valve or operate a typical fail closed pneumatic Safety System. The 11LV36 Relay **does not have** a Pin Button (Latch Pin or Manual Override) assembly.

The 11LV36 Relay has special internal components that allows for easy Push-To-Shut-In (manual override shutdown). This feature allows the facility operator to close the safety valves (during an ESD situation) with much less effort than standard function Manual Reset Relays.

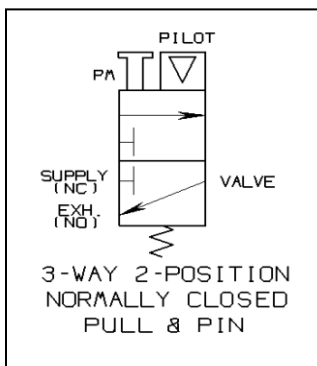

PARTS LIST:

- | | |
|------------------|--------------------|
| 1. Handle | 10. O Ring * |
| 2. Jam Nut | 11. Spiral Ring |
| 3. Valve Plunger | 12. O Ring * |
| 4. Panel Nut | 13. Valve Body |
| 5. O Ring (2) * | 14. Valve Spool |
| 6. O Ring * | 15. Washer |
| 7. O Ring * | 16. O Ring * |
| 8. O Ring * | 17. Piston |
| 9. Spring * | 18. Piston Housing |

* Indicates parts included in a Repair Kit

Sigma Model Number 11LV36

1/4" FEMALE NPT, PULL TO OPEN, H2S SVC

Product Specifications

Manual Reset (Operate) Feature: Pull & Hold to Open (Bypass Pilot Circuit) – Push to Close

Flow Control Application: Normally Closed

Control Function: Three-Way (Block & Bleed)

Pressure Rating Body (Control Ports): 250 PSI (17.24 Bar) maximum

Pilot Supply Pressure: Normal Operating Pressure 50 – 200 PSI
(Maximum Pressure Rating 200 PSI)

Instrument Supply Service at Control Ports: Pneumatic or Hydraulic

Manual Override Capability: Pull (Operator Hold - No Latch Pin or Lock-Out)

Connection Size: 1/4-18 Female N.P.T. Pilot, Supply, Valve, Exhaust

Panel Mount: Yes

Panel Hole Cutout Size Required: 1-3/8 Diameter

Orifice: .218 Diameter **Cv Factor:** 0.52

Seal Material: Viton

Component Material (Metal): 316 Stainless Steel

Weight: 4 Lbs.

Operating Temperature: -20° F to +250° F (-29° C to +121° C)

Overall Dimensions: 6-1/2 Height x 2-1/8 Diameter (16.5 cm Height x 5.4 cm Diameter)

Pressure Equipment Directive (PED): This product conforms to the SEP Category of the European P.E.D.

Installation and Maintenance Instructions:

Remove the Handle (#1) and the Panel Nut (#4). Insert the Valve in a pre-drilled 1-3/8" diameter hole. Replace the Panel Nut and Handle. Sigma recommends the use of appropriate thread sealant for each port connection.

Shelf Position Port Status

Pilot	Pilot Supply Inlet (Pneumatic On/Off Operating Pressure)
Supply	Inlet (Instrument Supply Pressure) normally closed
Valve	Outlet Pressure to Receiving Control Circuit (Open to Exhaust Port)
Exhaust	Depressurizes Receiving Control Circuit

Repair Kit Information

Repair Kits contain all of the Seals and other components typically replaced when repairing the assembly. In order to maintain optimum operating control function.